



CLIMATECARE

Deluxe 13+ SEER Heat Pumps

THJD Features:

- *Small attractive square footprint, fits most landscaping designs*
- *Efficiency ratings of up to 14+ SEER & 8.2 HSPF when matched with Variable Speed Indoor Section*
- *Environmentally friendly R410a Refrigerant*
- *Titanium colour matted-textured finish with special primer formulas to ensure less fading when exposed to sunlight*
- *Compressor protected with high pressure relief and temperature sensor for added longevity*
- *High Grade Louvered Metal Coil Guard for extra protection.*
- *Solid Core Liquid line filter drier for Compressor protection*
- *Sound Isolated motor & Rigid top panel for quieter air flow pattern*
- *Cushioned compressor mounts to dampen vibrations*
- *Quality copper tube aluminum fin construction for reliability*
- *Standard 5 year parts warranty, but if registered online within 90 days of purchase upgrades to 10 year total parts warranty*

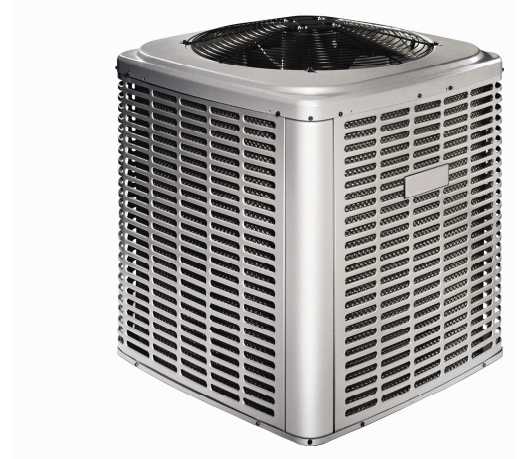

You can choose a THJD Heat Pump as part of your Hybrid Comfort System that lets you shift from the efficiency of an electric Heat Pump to the added power of a high efficiency gas furnace for the most efficient heating you've ever experienced

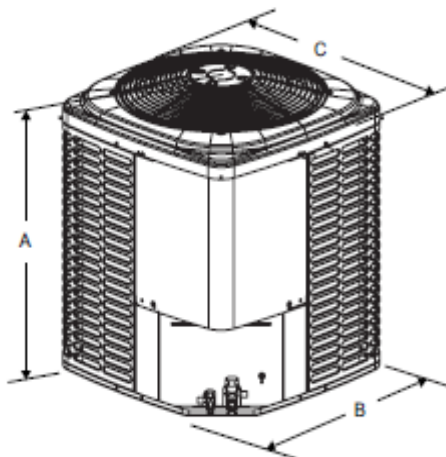

All dimensions are in inches. They are subject to change without notice. Certified dimensions will be provided upon request.

Unit Model	Dimensions (Inches)			Refrigerant Connection Service Valve Size	
	A ¹	B	C	Liquid	Vapor
18	28	34	34	3/8"	3/4"
24	32	34	34		
30	36	34	34		
36	40	34	34		
42	40	34	34		7/8"
48	40	34	34		
60	40	34	34		

1. Including Fan Guard.